

# AN8389S

## 4 Channel Linear Driver IC

### ■ Description

The AN8389S is a monolithic integrated circuit which employ 4 channel H-bridge system that they are suitable for driving motor or actuator of CD player. Also they employ the surface mounting type package superior in radiation characteristics.

### ■ Features

- Wide output D-range, regardless of the system reference voltage
- Built-in 4-channel BTL driver best suited for driving motors or actuators of 5 to 20Ω load
- Built-in thermal shutdown circuit (with Hysteresis)
- Separation between the signal and output line power supplies, allowing control of IC heating
- Reset output pin
- Shorting brake mode

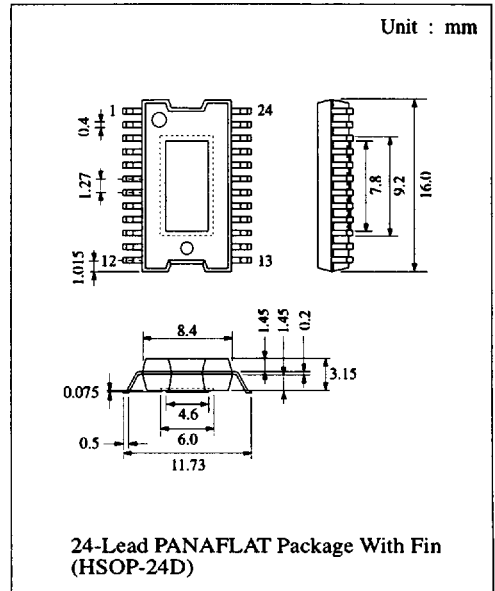

### ■ Block Diagram

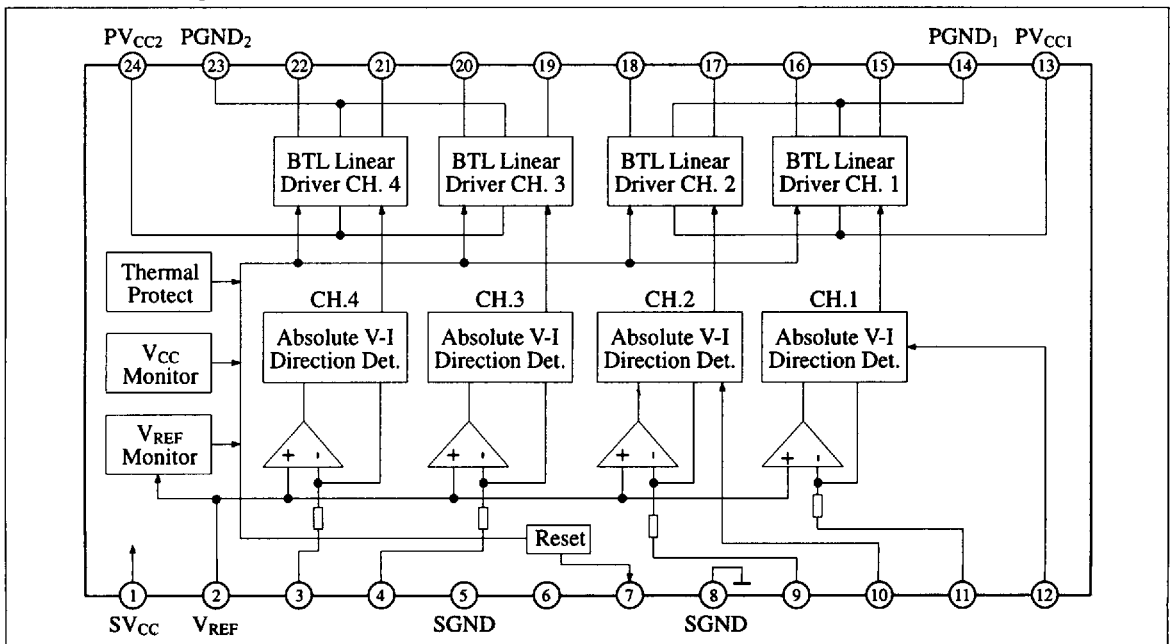

## ■ Absolute Maximum Ratings (Ta=25°C)

Item	Symbol	Rating	Unit
Supply Voltage	V <sub>CC</sub>	20	V
Output Current	I <sub>out</sub>	500	mA
Power Dissipation	P <sub>D</sub>	1420	mW
Operating Ambient Temperature	T <sub>opr</sub>	-20 ~ +75	°C
Storage Temperature	T <sub>stg</sub>	-55 ~ +150	°C

Operating Supply Voltage Range: PV<sub>CC</sub>, SV<sub>CC</sub> = 4.7V ~ 16.0V

## ■ Electrical Characteristics (Ta=25°C)

Item	Symbol	Condition	min.	typ.	max.	Unit
Total Circuit Current	I <sub>tot</sub>	PV <sub>CC1</sub> = PV <sub>CC2</sub> = SV <sub>CC1</sub> = 8V	10	20	30	mA

### Drivers 1 to 4

Item	Symbol	Condition	min.	typ.	max.	Unit
Input Offset Voltage	V <sub>IOF</sub>	PV <sub>CC1</sub> = PV <sub>CC2</sub> = SV <sub>CC1</sub> = 8V, R <sub>L</sub> = 18Ω, R <sub>in</sub> = 10kΩ	-7		7	mV
Output Offset Voltage	V <sub>OOF</sub>		-50		50	mV
Gain (+)	G <sub>+</sub>		15.5	18.5	21.5	dB
(+) Relative Gain	ΔG		-1.0	0	1.0	dB
Limit Voltage (+)	VL <sub>+</sub>		4.95	5.3		V
Limit Voltage (-)	VL <sub>-</sub>			-5.3	-4.95	V
Dead Zone Width	V <sub>DZ</sub>		-10		20	mV

### Drivers 1 and 2, PC Operation

Item	Symbol	min.	typ.	max.	Unit
Threshold H	V <sub>FCH</sub>	14			V
Threshold L	V <sub>PCL</sub>			0.5	V

### Reset Circuit

Item	Symbol	min.	typ.	max.	Unit
Reset Operation Release Supply Voltage	V <sub>RST</sub>	4.2	4.6	4.85	V
Threshold Hysteresis Width	V <sub>HYS</sub>	0.09	0.17	0.31	V
V <sub>REF</sub> Detection	V <sub>R</sub>	1.85			V

### Heat Protection Circuit

Item	Symbol	min.	typ.	max.	Unit
Operation Temperature Equilibrium Value*1	T <sub>THD</sub>		(150)		°C
Operation Temperature Hysteresis Width*1	ΔT <sub>THD</sub>		(20)		°C

\*1 : Characteristics value in parentheses is a reference value for design but not a guaranteed value.

## Application Circuit

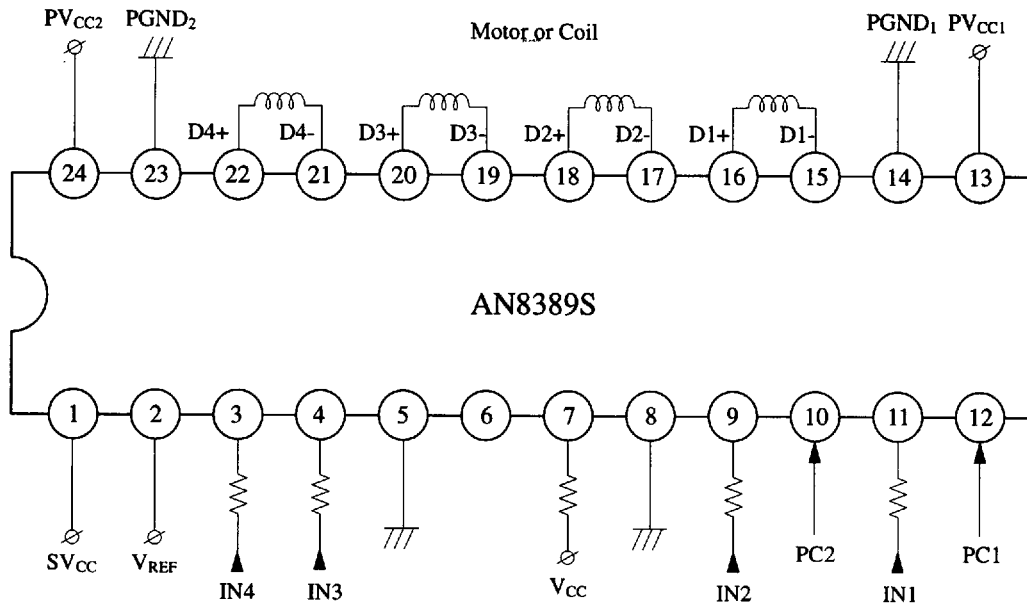

## Pin Descriptions

Pin No.	Pin Name	I/O	DC Voltage (V <sub>CC</sub> = 8V)	Equivalent Circuit	Description
1	Power Supply (SV <sub>CC</sub> )	I	8V		PC (power cut) input pin controlling the output of Pin 15 and Pin 16.
2	V <sub>REF</sub> Input	I	2.5V		V <sub>REF</sub> input pin.
3	Motor Driver 4 Input (IN <sub>4</sub> )	I	2.5V		Error input pin of Driver 4.
4	Motor Driver 3 Input (IN <sub>3</sub> )	I	2.5V		Error input pin of Driver 3.
9	Motor Driver 2 Input (IN <sub>2</sub> )	I	2.5V		Error input pin of Driver 2.
11	Motor Driver 1 Input (IN <sub>1</sub> )	I	2.5V		Error input pin of Driver 1.
5 8	GND	I	0V		GND pin for control circuit of driver.
6	No Connection (NC)				
7	Reset Output (NRESET)	O			Reset output pin.

■ Pin Descriptions

Pin No.	Pin Name	I/O	DC Voltage (V <sub>CC</sub> = 8V)	Equivalent Circuit	Description
10	Power Cut Input 2 (PC2)	I	0V		PC (power cut) input pin controlling the output of Pin 15 and Pin 16.
12	Power Cut Input 2 (PC1)	I	0V		PC (power cut) input pin controlling the output of Pin 17 and Pin 18.
13	Power Supply 1 for Driver (PVCC1)	I	8V		Power V <sub>CC</sub> pin, supplying the current flowing for output power transistors of Pin 15, 16, 17 and 18.
24	Power Supply 2 for Driver (PVCC2)	I	8V		Power V <sub>CC</sub> pin, supplying the current flowing for output power transistors of Pin 19, 20, 21 and 22.
14	GND 1 for Driver	I	0V		GND pin for output power transistors of Pin 15, 16, 17 and 18.
23	GND 1 for Driver	I	0V		GND pin for output power transistors of Pin 15, 16, 17 and 18.
15	Motor Driver 1 Reverse Output (D1-)	O	0V		Reverse rotation output pin of Driver 1.
16	Motor Driver 1 Forward Output (D1+)	O	0V		Normal rotation output pin of Driver 1.
17	Motor Driver 2 Reverse Output (D2-)	O	0V		Reverse rotation output pin of Driver 2.
18	Motor Driver 2 Forward Output (D2+)	O	0V		Normal rotation output pin of Driver 2.
19	Motor Driver 1 Reverse Output (D3-)	O	0V		Reverse rotation output pin of Driver 3.
20	Motor Driver 1 Forward Output (D3+)	O	0V		Normal rotation output pin of Driver 3.
21	Motor Driver 2 Reverse Output (D4-)	O	0V		Reverse rotation output pin of Driver 4.
22	Motor Driver 2 Forward Output (D4+)	O	0V		Normal rotation output pin of Driver 4.

## ■ Supplementary Explanation

### ● Cautions for use

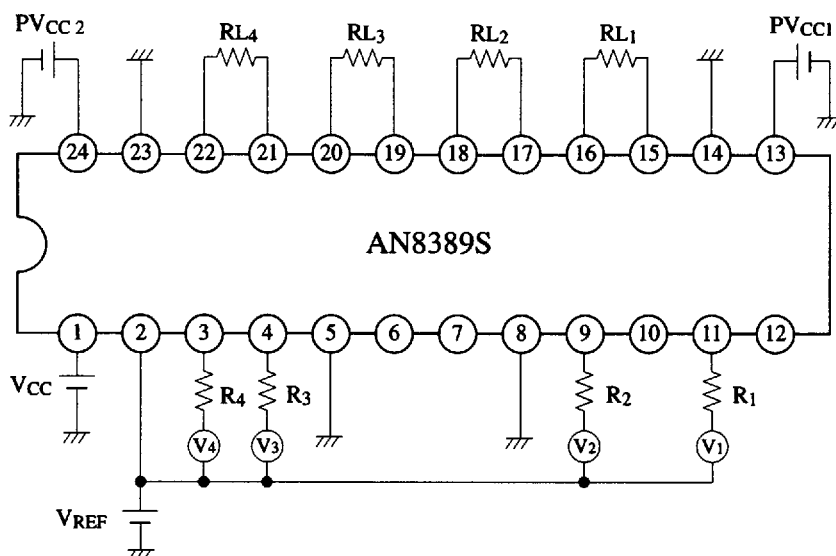

When using AN8389S, refer to the following notes and follow the power dissipation characteristics curve.

- (1) The load current,  $I_{P1}$ , passing through loads  $RL1$  and  $RL2$  is supplied through pin No.13.

$$I_{P1} = I_{V16-15}/RL1 + I_{V18-17}/RL2$$

- (2) The load current,  $I_{P2}$ , passing through loads  $RL3$  and  $RL4$  is supplied through pin No.24.

$$I_{P2} = I_{V20-19}/RL3 + I_{V22-21}/RL4$$

- (3) The dissipation increment,  $\Delta P_D$ , in the IC (power output step) through loads  $RL1$ ,  $RL2$ ,  $RL3$  and  $RL4$  is as follows.

$$\begin{aligned} \Delta P_D = & (PVCC1 - I_{V16-15}) \times I_{V16-15}/RL1 \\ & + (PVCC1 - I_{V18-17}) \times I_{V18-17}/RL2 \\ & + (PVCC2 - I_{V20-19}) \times I_{V20-19}/RL3 \\ & + (PVCC2 - I_{V22-21}) \times I_{V22-21}/RL4 \end{aligned}$$

- (4) The dissipation increment,  $\Delta P_S$ , in the IC (signal block, supplied from pin No.1) through loads  $RL1$ ,  $RL2$ ,  $RL3$ , and  $RL4$  is approximately as follows.

$$\begin{aligned} I_T = & I_{V1}/R1 + I_{V2}/R2 + I_{V3}/R3 + I_{V4}/R4 \\ \Delta P_S = & V_{CC} \times I_T \times 10 + V_{CC} \times (I_{P1} + I_{P2}) \times 10^{-2} \end{aligned}$$

- (5) The dissipation increment of the IC, when the driver operates, is  $\Delta P_D + \Delta P_S$ .